

Bundle Decomposer JBF 150/90

for bags and hollow containers. Designed for sustained, continuous and thus *highly profitable* operation with less dysfunction emerge and maintenance need.

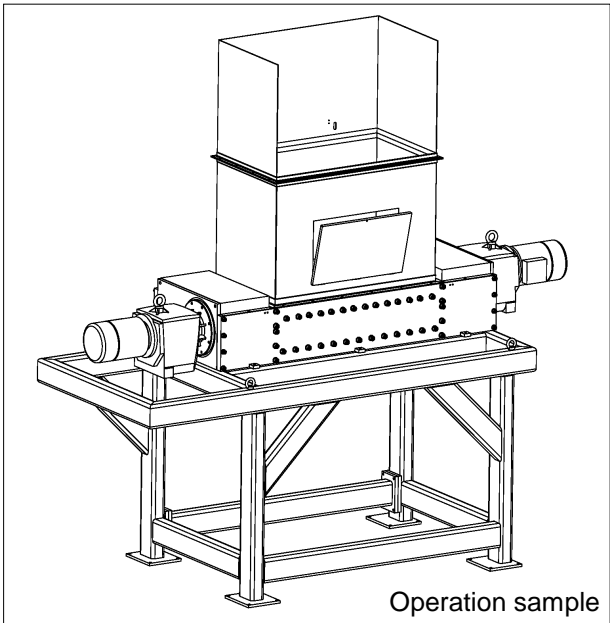

- drive: load-dependent max. 2 x 11 kW, optional 2 x 15 kW (idle running load approx. 6-8 kW only)
- high energy efficiency with automatic adaption of energy consumption to factual need through material quantity and its specification
- knife width 60 mm
- no material taping / wrapping of knife shafts
- low need for cleaning and cut releasing of the working unit
- throughput approx. 8 - 10 to/h, eventually more with continuous feeding
- plugging-free process by sophisticated working and operation principle
- nearly 100 % opening and discharging rate
- hardened opening tools
- exchangeable wear parts, to be changed inside the machine, reclaimable wear parts
- less wear appearance
- ***no hydraulic system requested***
- compact design with bevel gear motors possible
- **assembly into existing installations possible**
- **integration into existing bunkers possible**

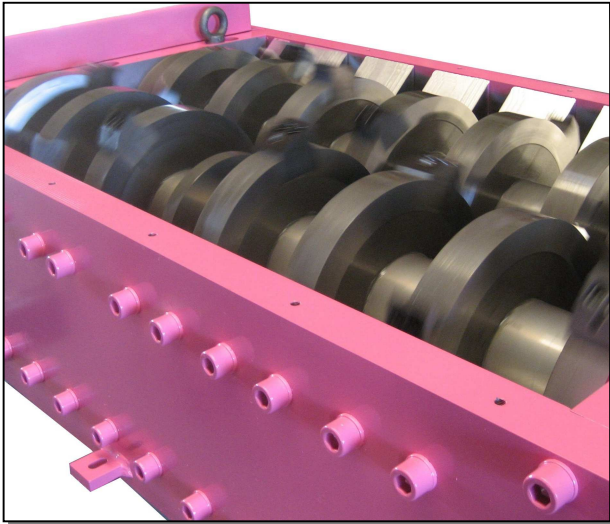