

[Hard Disk Drive Shredder JBF HD 54/60](#)

The JBF HD 54/60 is a powerful solution for destruction of nearly all commonly used Hard Disk Drives. The solid and reliable industrial cutting unit with its powerful drive shreds actually used HDD's to 40 mm wide pieces. Fully automated control of all functions via a brand name PLC makes operation very simple and saves human resources. For most flexible use the HD 54/60 can be easily moved with two hand pallet trucks, requires only 3 sqm space and a three-phase supply Cekon CEE 32A for operation.

Via a slot in the cover of the feed hopper the **shredding material is fed continuously** into the hopper made of solid steel panels. Due to the perfect adjustment of knives and cutting speed the material will be destroyed independently. When lifting the top cover of the hopper, even larger media or several HDDs can be processed in parallel. For maximum safety a limit switch will cut-off the shredder as long as the top-cover is open.

The **solid cutting unit** is equipped with **40 mm wide cutters** and a **strong 9.2 kW geared motor** for industrial use. The shape of the cutting knives is **especially adapted for HDD-shredding** and ensures thereby best possible grabbing of the shredding material. The cutting unit was constructed for long-term industrial use. Rack, cutting unit and combs are especially designed for low maintenance.

The **solid rack made of rectangle steel tube** allows to place a 1m³ BigBag underneath (not included in the price) for collection of the shreds. A solid sheet steel door with limit switch protection provides for maximum safety. For **convenient transportation to other points of use** the machine can be moved with two hand pallet trucks.

All operation buttons and indicator lights plus emergency-switch and main on / off switch are combined in one central console. All electrical items like contactors, overload protection switches, emergency-stop-relay, main switch, transformers and terminals are clearly arranged in the central control cabinet. All **functions are controlled fully automatically** by a specially programmed Eaton easy PLC.

[Optional bulk storage solution for 1 m³ BigBags](#)

This proven product allows for fast and convenient attachment of a 1 m³ BigBag and easy manoeuvrability of the filled BigBag with a hand pallet truck. It offers 1,500 kg load capacity and can be stacked 4 times for space saving storage of larger quantities of big bags. It weighs 50 kg only and features an integrated register for manual discharge of bulk material from BigBags with nozzle at the bottom.

[30 mm wide cutters](#)

For creation of smaller bits and pieces the machine can be equipped as an alternative with 30 mm wide cutters instead of the 40 mm wide standard cutters.

JBF HD 54/60 industrial shredder

Feeding hopper

Description:

Solid welded feed hopper made of sheet steel. With feed slot for continuous feeding of 3.5" HDD's. Foldable cover from sheet-steel with handle for feeding of large-format-media, secured with limit-switch, aided by a gas spring.

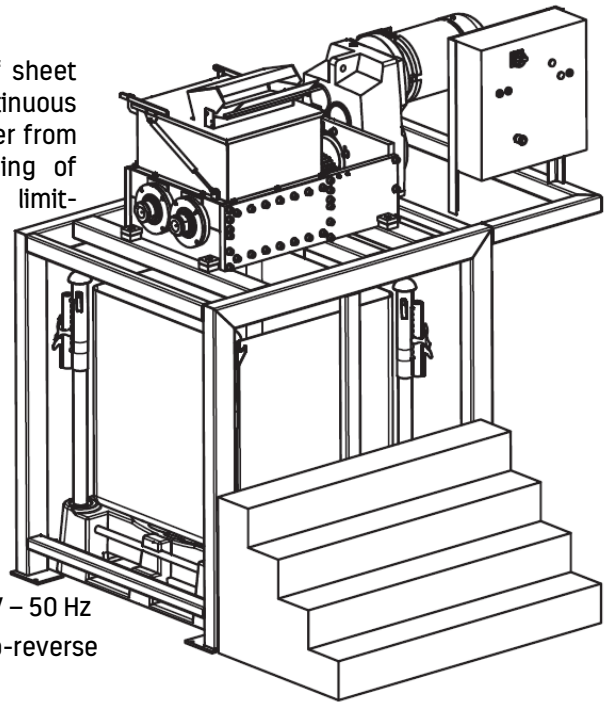

Cutting block 40 mm strip cut

Cutting zone:

app. 540 x 600 mm

Cutting cylinders:

2

Working width:

540 mm

Cutting width:

40 mm strip cut

Sound level:

about 70 dBA idling

Drive:

electric geared motor 9.2 kW – 400 V – 50 Hz

Overload protection:

electronic torque limitation with auto-reverse

Plug:

CEKON-plug CEE 32 A

Fusing:

35 A slow blow, by customer

Function control:

EATON Easy 512 PLC

Throughput:

up to approx. 400 HDD's 3.5" per hour

Description:

Cutting shafts assembled from single exchangeable knives and cams, knives are deeply hardened to special specification. The cutters are designed for the purpose of cutting HDD's. Also CD's, DVD's, video-cassettes, dlt-tapes and other magnet tapes, electronic circuit boards and the like can be processed. Automatic monitoring of the shredder via central controlling unit.

Complete rack

Description:

Stable welded profile steel construction. Solid sheet steel covers. Integrated door for access to receptacle for shreds, equipped with safety switch (as soon as the door is opened, the shredder is stopped). Painted RAL7035 light-grey.

Control elements

Main Switch

Connects the machine with the power supply

Emergency Stop Switch

Immediate disconnection of the machine in case of emergency

Pushbutton "Start"

pushing the tracer starts the machine via PLC

Pushbutton "Stop"

pushing the tracer stops the machine via PLC

Reverse Tracer

pushing the tracer reverses the cutting cylinders

Warning Lights

control voltage available / machine is in operation

Safety Switch

opening the access door to receptacle + lifting the cover of the feed hopper causes emergency stop



Bulk Storage Solution for BigBags

Allows for fast and convenient attachment of a 1 m³ BigBag
Easy manoeuvrability of the filled BigBag with a hand pallet truck.
Manual discharge of bulk goods (BigBags with nozzle at the bottom)

Technical Data

Suitable BigBags:	95 x 95 cm base Strap length 30 to 35 cm
Load capacity:	1,500 kg
Stackability:	max. 4 times 1,500 kg
Bag emptying:	manually via integrated register
Temperature range:	-10 up to +40°C

