

**Fellowes**  
THE WORLD'S TOUGHEST SHREDDERS

**POWERSHRED**

## Help Line

Australia	+ 1-800-33-11-77
Canada	+ 1-800-665-4339
México	+ 1-800-234-1185
United States	+ 1-800-955-0959

## Fellowes

Australia	+ 61-3-8336-9700
Benelux	+ 31-(0)-76-523-2090
Canada	+ 1-905-475-6320
Deutschland	+ 49-(0)-5131-49770
France	+ 33-(0)-1-30-06-86-80
Italia	+ 39-(0)-71-730041
Japan	+ 81-(0)-3-5496-2401
Korea	+ 82-(0)-2-3462-2884
Malaysia	+ 60-(0)-35122-1231
Polska	+ 48-(22)-771-47-40
Spain	+ 34-91-748-05-01
Singapore	+ 65-6221-3811
United Kingdom	+ 44-(0)-1302-836836
United States	+ 1-630-893-1600

**www.fellowes.com**



**P-55C**

Please read these instructions before use.

**Fellowes**, 1789 Norwood Avenue Itasca, Illinois 60143-1095 630-893-1600

<http://www.fellowes.com>

Australia Benelux Canada France Deutschland Italia Japan Korea Polska Singapore United Kingdom

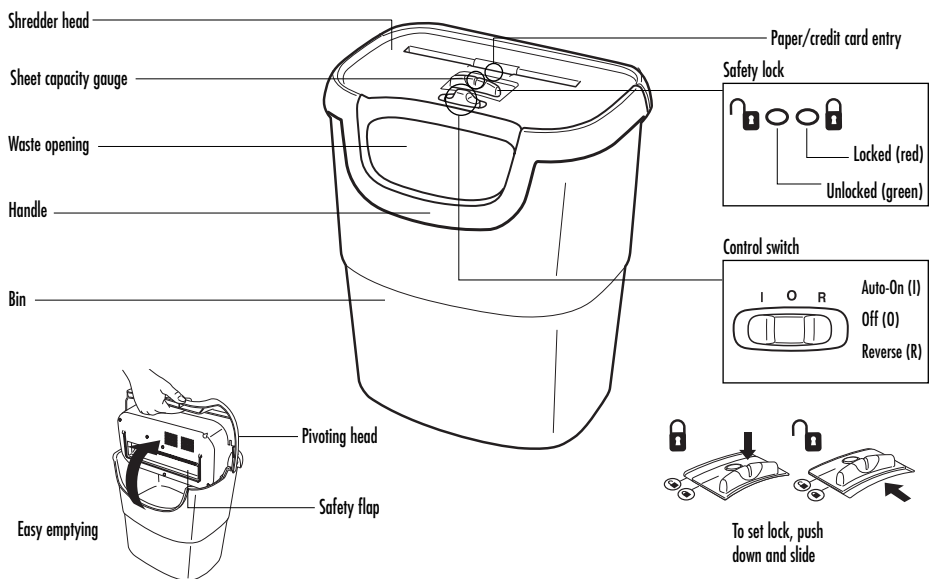

## CAPABILITIES

**Will shred:** Paper, credit cards and staples

**Will not shred:** Continuous forms, adhesive labels, transparencies, newspaper, cardboard, paper clips, laminates or plastic other than noted above

**Paper shred size:**

Confetti-Cut ..... 5/32" x 2" (3.9 x 50mm)

**Maximum:**  
 Sheets per pass (Confetti-Cut) ..... 8\*  
 Passes per day ..... 10-20  
 Cards per pass ..... 1  
 Cards per day ..... 10  
 Paper width ..... 9"/229mm  
 Continuous operation ..... 5-7 minutes

\*20lb., 8.5"x11" paper at 120v, 60Hz, 2.0 Amps; heavier paper, humidity or other than rated voltage may reduce capacity.

## IMPORTANT SAFETY INSTRUCTIONS — Read Before Using!

### WARNING

- Keep away from children and pets. Always unplug or set safety lock when not in use.
- Keep foreign objects – gloves, jewelry, clothing, hair, etc. – away from shredder openings. If object enters top opening, switch to Reverse (R) to back out object.

- Never use aerosol, petroleum-based or other flammable products on or near shredder. Do not use canned air on shredder.
- Do not use if damaged or defective. Do not open shredder head. Do not place near or over heat or water source.

### CAUTION

- Avoid touching exposed blades under Confetti-Cut shredder head.

## OPERATION

Insert waste bag (Fellowes #36052) for easy disposal.



**Continuous operation:**  
5-7 minute maximum

**NOTE:** Shredder runs briefly after each pass to clear entry. Continuous operation beyond 5-7 minutes will trigger 20-minute cool down period.

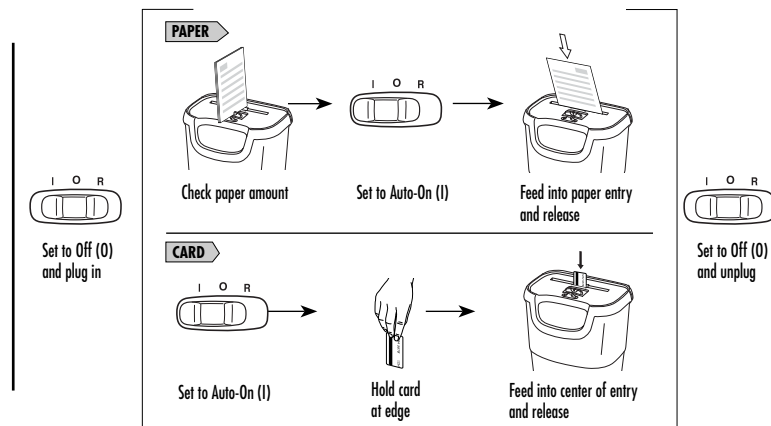

**Safety Lock** prevents accidental operation. To set, wait for shredding to stop, push black button down and slide until you see red. To unlock push black button down and slide until you see green. For greater safety, always unplug shredder after use.

## TROUBLESHOOTING

**Paper jam:** Set to Off (O), remove shredder head and empty bin. Replace shredder head, and follow any or all of the below procedures.

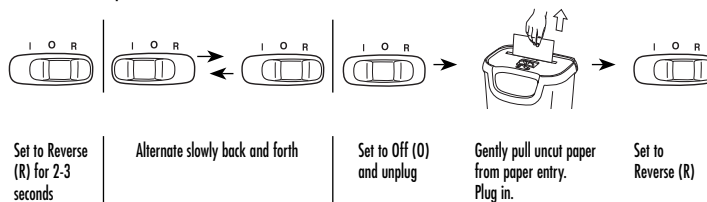

**Shredder doesn't start:**

- Make sure head is on basket correctly
- Wait 20 minutes for motor to cool down
- Remove and empty basket
- Make sure safety lock is in unlock (green) position

## MAINTENANCE

Run regularly in reverse for one minute

Lubricate when bin is full, or immediately, if:

- Capacity decreases
- Motor sounds different, or Shredder stops running

Follow oiling procedure below and repeat twice.

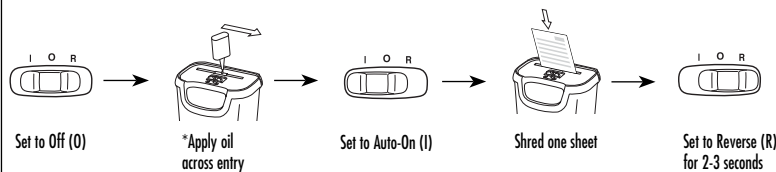

**CAUTION** \*Only use a non-aerosol vegetable oil in long nozzle container

## WARRANTY

**LIMITED WARRANTY** Fellowes, Inc. ("Fellowes") warrants the cutting blades of the machine to be free from defects in material and workmanship for 3 years from the date of purchase by the original consumer. Fellowes warrants all other parts of the machine to be free from defects in material and workmanship for 1 year from the date of purchase by the original consumer. If any part is found to be defective during the warranty period, your sole and exclusive remedy will be repair or replacement, at Fellowes' option and expense, of the defective part. This warranty does not apply in cases of abuse, mishandling, or unauthorized repair. ANY IMPLIED WARRANTY, INCLUDING THAT OF MERCHANTABILITY OR

**FITNESS FOR A PARTICULAR PURPOSE,** IS HEREBY LIMITED IN DURATION TO THE APPROPRIATE WARRANTY PERIOD SET FORTH ABOVE. In no event shall Fellowes be liable for any consequential or incidental damages attributable to this product. This warranty gives you specific legal rights. The duration, terms, and conditions of this warranty are valid worldwide, except where different limitations, restrictions, or conditions may be required by local law. For more details or to obtain service under this warranty, please contact us or your dealer.