

Hard disc shredder type JBF HD 14.6

Shredding system JBF HD14.6 for hard discs and other data carrier, designed for flexible and mobile applications.

This type of shredding machine is designed for the shredding of hard discs, CD/DVD, video tapes, typewriter ribbon, retaining tape etc. With its reduced overall width of 760 mm it was designed for the move through standard door widths.

14.6 mm knife width cares for small particle sizes and thus for more data security. The 4 kW drive with gear motor allows high cutting performance by its enormous torque. A low shaft speed of 11 rpm avoids sparking inside the cutting unit.



Shown with with 120 litre container
(not included in standard package)

Latest safety standards apply secured feeding of material into the running shredder through special funnel with electrical safety switch. Max. size of parts: 200 x 114 x 40 mm (l x w x h). Feeding of larger parts is possible when shredder is stopped, lid closed and with manual machine start (old 5.5" hard discs, DVD stack on spindle, PET bottles, cans etc.).

Auto Reverse at overload with automatic restart. Machine stops after triple reverse. By direct drive of cutting shafts drive chains are not needed. Thus less maintenance requested along with low dust sensitivity.

Basic frame for 120 litre container (container not included). Space-saving location of electrical cabinet, integrated inside machine frame.



Feeding channel for manual feeding of hard discs

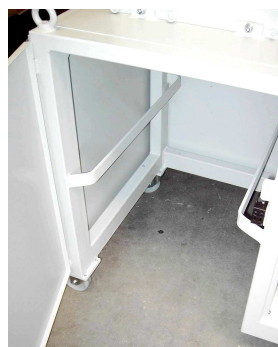

solid steel frame
for standard 120litre wheelie bin

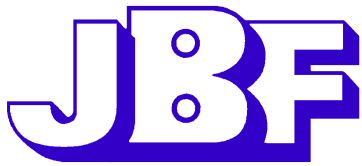

Shredding Technology

Volume reducing
Paper shredding
Data carrier shredding

Hard disc shredder type JBF HD14.6



The JBF HD14.6 is easily moved with large lockable rollers



Before and after shredding with JBF HD 14.6

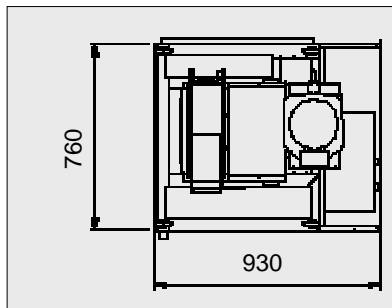
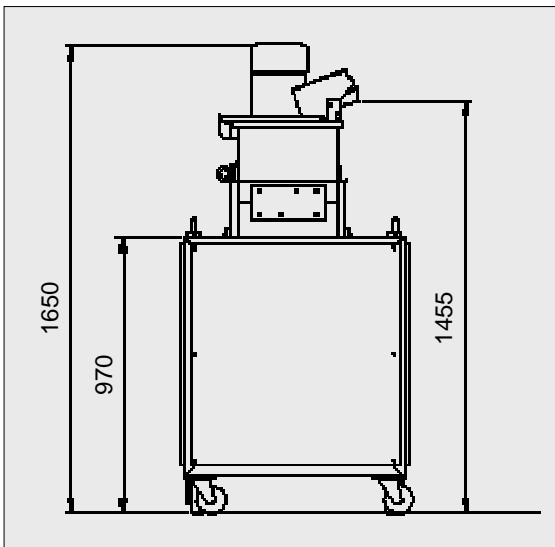

(measurements in mm)

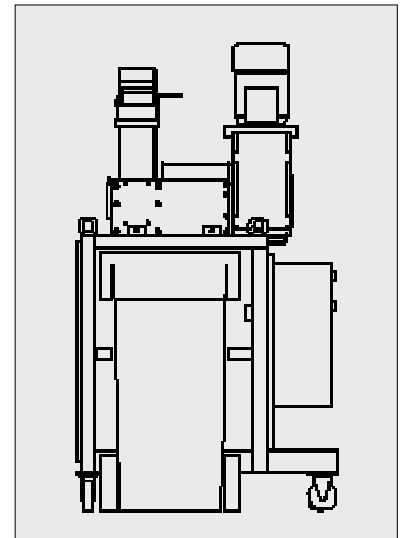

Technical data JBF HD14.6 :

Knife width	14.6 mm	measurements	
Cutting zone	approx. 120 x 350 mm	Length	approx. 930 mm
Cutting speed	approx. 11 rpm.	Width	approx. 760 mm
Container volume	120 l	Overall height	approx. 1650 mm
Power supply	400 V / 50 Hz	Insertion height	approx. 1455 mm
Connected load	4 kW	Weight	approx. 290 kg
Throughput:	approx. 5 hard discs 3.5" per minute - (3.5"-hard disc = 100mm x 150-200mm x 30 mm W x L x H)		

Don Ruffles Ltd.
138 Victoria Road, Horley. Surrey RH6 7BF
Tel: 0845 5555 007 Fax: 0845 5555 008
Web: www.shreddingmachines.co.uk
email: clive@donruffles.co.uk

Subject to technical modifications.



e&oe