

HSM®

OPERATING INSTRUCTIONS PAPER SHREDDER



HSM FA 500.2

english



Keep this instruction for future use!

1.655.999.112 – 1002

Contents

1	Proper use, warranty.....	3
2	Safety instructions.....	3
3	Overview	4
4	Dimensions	5
5	Transportation, installation	6
6	Operating and display elements on the keypad.....	7
7	Start-up and inspecting the safety devices	8
8	Malfunctions.....	10
9	Maintenance and care	10
10	Technical data.....	13
11	Electric wiring diagrams for Solo- and Combination-version	14

HSM (UK) Ltd.

14, Attwood Road / Zone 1
Burntwood Business Park
Burntwood
Staffordshire
WS7 3GJ
United Kingdom

Phone: +44 (0) 1543 272 480

Fax: +44 (0) 1543 272 080

info@hsmuk.co.uk

www.hsmuk.co.uk

HSM of America LLC

419 Boot Road
Downingtown, PA 19335
USA

Phone: 001 610 918 4894

Fax: 001 610 918 4899

customerservice@hsmofamerica.com

info@hsmofamerica.com

www.hsmofamerica.com

HSM®

HSM GmbH + Co. KG

Austrasse 1-9
88699 Frickingen / Germany

Tel. +49 7554 21 00-0

Fax. +49 75 54 2100 160

info@hsm.eu

www.hsm.eu

1 Proper use, warranty

The document shredder is designed for destroying paper and cardboard, as well as store cards, credit cards, CD-ROMs and floppy discs. Its sturdy drive mechanism is not damaged by paper clips and staples and is even suitable for shredding whole files and folders.

Our general business conditions are applicable. We provide a one year warranty for the document shredder. The warranty period is 6 months when used in multiple shifts. This warranty excludes wear, damage due to improper handling, natural depreciation, and actions taken by third parties.

2 Safety instructions



Caution:

It is prohibited to operate one only machine of a combination-version machine.

- Before using the machine for the first time, read the operating manual, and keep it for later use and to pass on to any subsequent users.
- Do not remove or modify safety devices which guarantee the safe operation of the machine.
- Observe all safety instructions attached to the machine.
- Carry out inspection and maintenance regularly.
- Switch off the shredder, disconnect the power plug and call customer service in the following circumstances:
 - power cables or plugs are damaged
 - liquid has entered the shredder
 - the shredder has been exposed to rain
 - the machine does not work properly despite the operating manual having been observed
 - the shredder has been damaged
- No platforms or other raised surfaces may be placed near the shredder if they encroach on the specified safety clearances.

Warning

- Ensure that no unauthorised persons can access the document shredder. Do not leave the document shredder switched on when it is unattended. The shredder may not be operated by anyone under 16 years of age. When the machine is not in use, it must be shut down and secured against unauthorised use. To do so, you can secure the mains switch with a padlock when it is in the off position.



Danger of injury

Do not reach into the paper feed opening.

Splinters can cause injury

Wear protective goggles when destroying diskettes, CDs and hard credit cards.

Danger of injury during intake

Do not go near the paper feed opening with long hair, loose clothing, ties, scarves, necklaces, bracelets etc. Do not destroy any material which might become tangled, such as tapes, binder ties or foil.

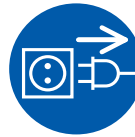

Switch off the shredder and pull out the power plug before moving or cleaning the shredder, or any other task outside its normal scope of use.



Maintenance and service tasks may only be performed by HSM customer service and service engineers of our dealers.

Operating controls for your safety

Emergency stop button

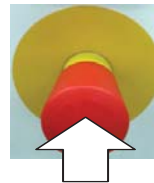

In the event of danger, press the emergency stop button immediately.

This switches off the shredder, and stops the cutting block and feed belt.

Main switch (only Solo-version)



In the event of danger, turn the main switch to "0".

You can secure the main switch in this position with a padlock to prevent restarting.

3 Overview



Combination with
HSM KP 80

- 1 Main switch (only solo-version)
- 2 Keypad
- 3 Emergency stop button
- 4 Loading tray
- 5 Intake conveyor,
paper feed opening
- 6 Braking swivel castors
- 7 Nameplate
- 8 Oiler

4 Dimensions

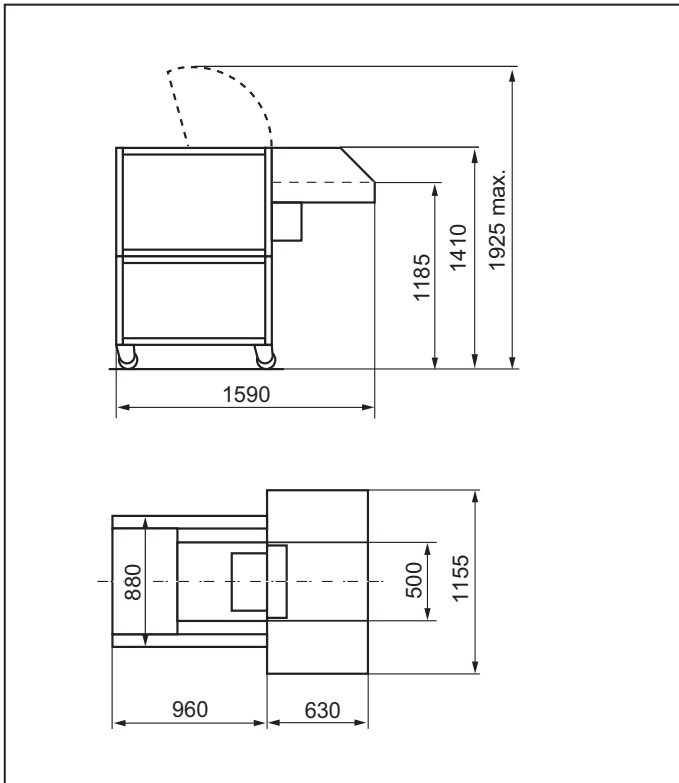

HSM FA 500.2 Combination-version

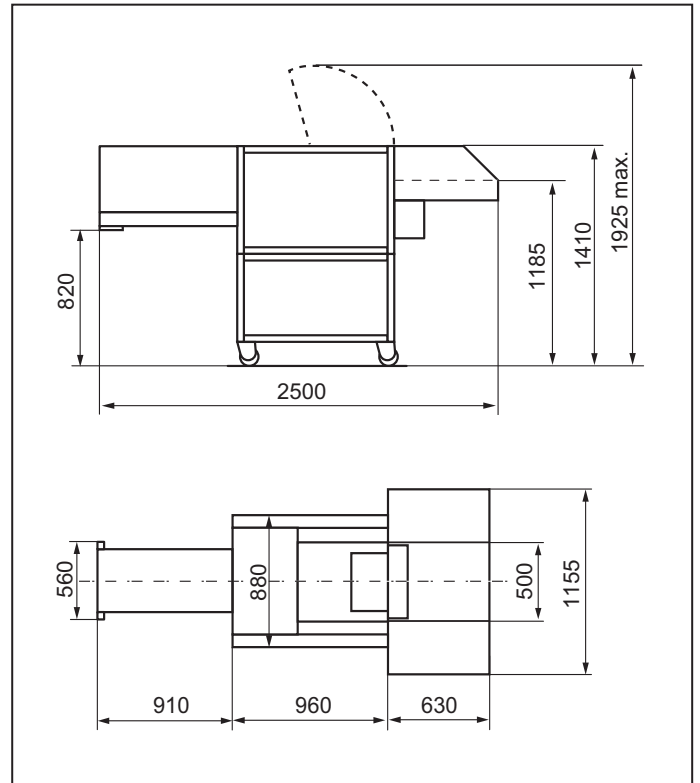

HSM FA 500.2 Stand alone-version

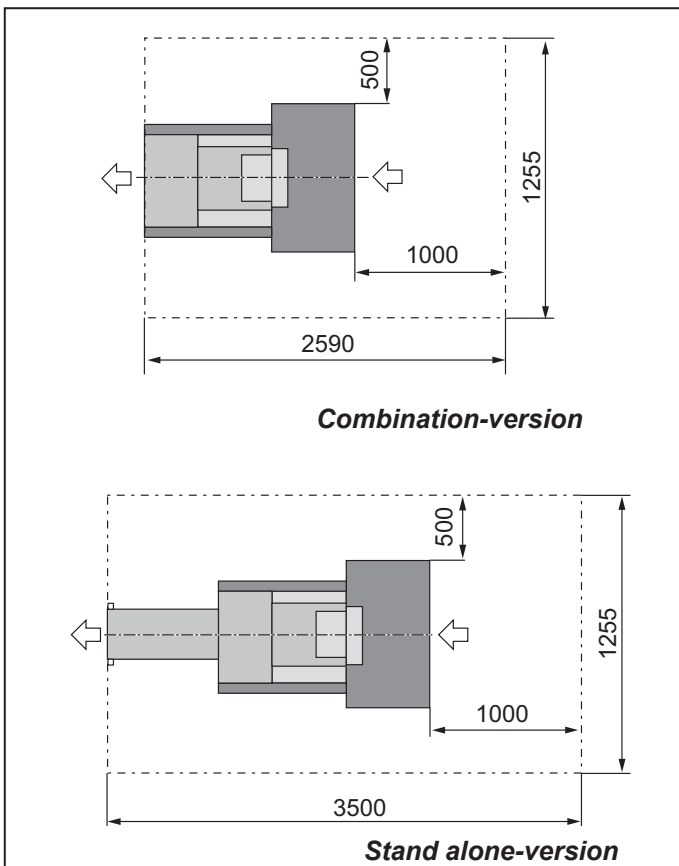

Space requirements for operation and maintenance

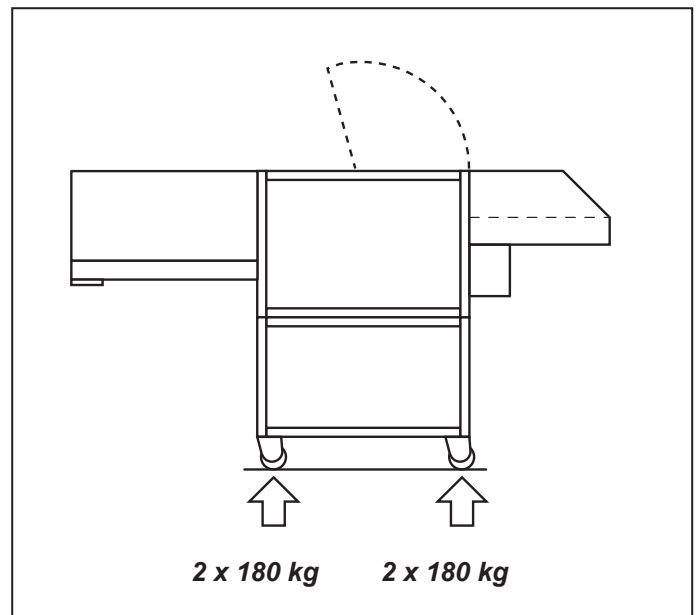

Load on rollers

5 Transportation, installation

- During transport, observe the high centre of gravity of the paper shredder!
- Place the pallet with the shredder in its packaging on a smooth, level surface.
- Observe the instructions for unpacking.
- If you need to move the shredder through narrow doors, you can wait until it is at its final location before fitting the loading tray. Without the tray, the machine is only 880 mm wide.
- The shredder may only be placed in dry rooms on a hard, level floor – not on carpets. The floor load on each roller is approximately 180 kg.
- The machine must be connected to a power source which meets the specifications on the nameplate. Make sure the power cable is unobstructed and that nobody can tread on it

Mount the loading table onto the unit:

- Remove screws (1) and (2) from the frame.

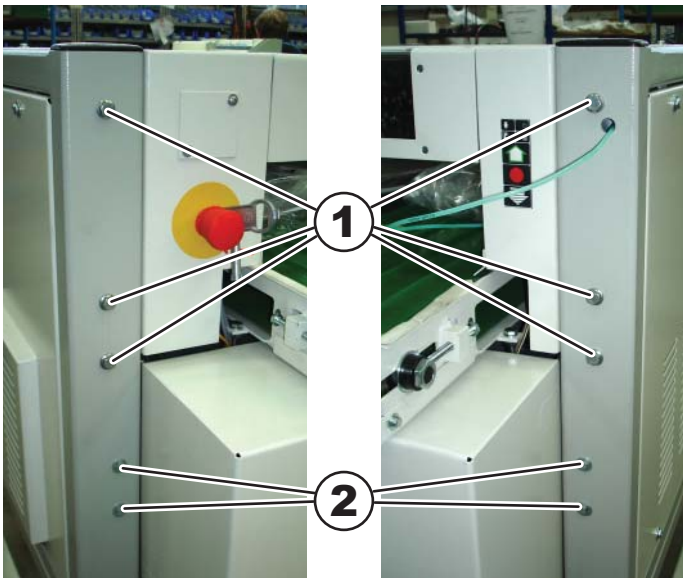

- Fasten the supports to the frame with the screws (2).



- Place the table on the supports. Make sure the oil hose is not bent. Fasten the table above (1) to the frame.

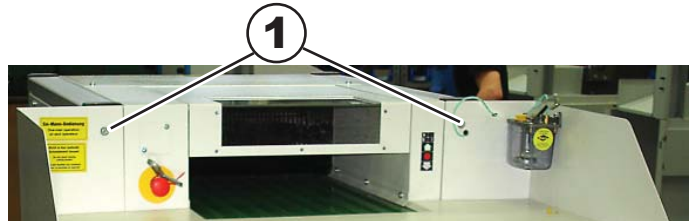

- Screw the table on with the hexagon bolts (1) also at the bottom of the frame and fasten to the supports with the bolts (3) and nuts (4).

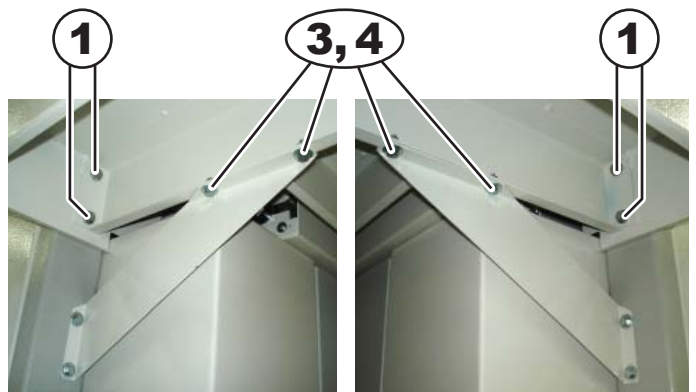

Mount the oil hose onto the unit:

- Guide the hose through the recesses in the table to the oiler and shorten the hose.

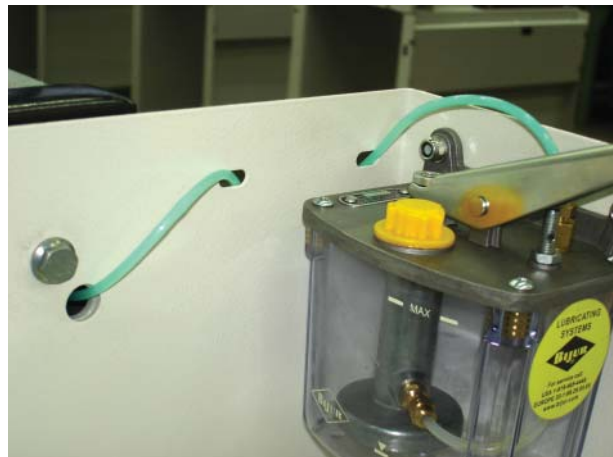

- Insert the connecting screw (5) and the clamp (6) on the end of the hose and secure the unit on the oiler.

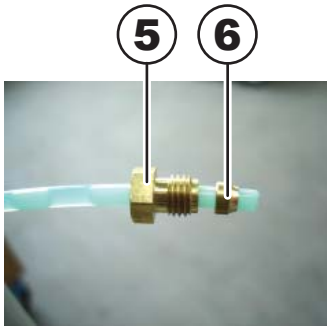

- **Solo machine:**
Lock the front castors by pressing down the brake lever.
- **Combination version:**
The assembly of the shredder with the baling press is described in the operator's manual of the Shredder press combination.

- Pour the oil into the oiler container from the two bottles supplied.

6 Operating and display elements on the keypad

- Paper jam or overload**
Red LED
- Safety circuit interrupted**
Red LED

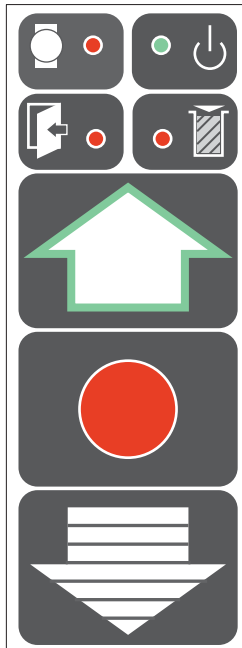

- Ready for operation**
Green LED
- Paper container full**
Red LED

Start button
The shredder switches on. The feed belt moves in the intake direction.

Stop button
The cutting block and feed belt stop. The shredder is in standby mode.

Reverse button
The cutting block and feed belt run in reverse.

7 Start-up and inspecting the safety devices



Check that the safety devices are working properly:

- At the start of each shift
- After any maintenance or repair work

Do not start the machine until you have checked the safety devices and found them to be in perfect working order. If any defect arises during operation stop the machine immediately and make sure it is corrected.

Switching on the paper shredder



- Unlock the emergency stop button by turning it anticlockwise.



- Solo-version: Turn the main switch to the I position.
Combination-version: Turn the main switch on the baling press to the I position.
▶ The green „Ready for operation“ LED lights up.



- Press the green start button.
▶ The cutting block and feed belt start up.



Caution!

The feed belt can run in reverse if the phase wires in the power plug are incorrectly connected.

Turn off the main switch immediately and pull out the power plug! Have an electrician change two of the three phase wires.

Checking the emergency stop button

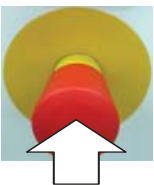

Press the emergency stop button while the machine is running. The shredder must switch off immediately. The cutting block and the feed belt must stop. The machine will only start again once you have pulled out the emergency stop button again.

Safety flap on the feed belt

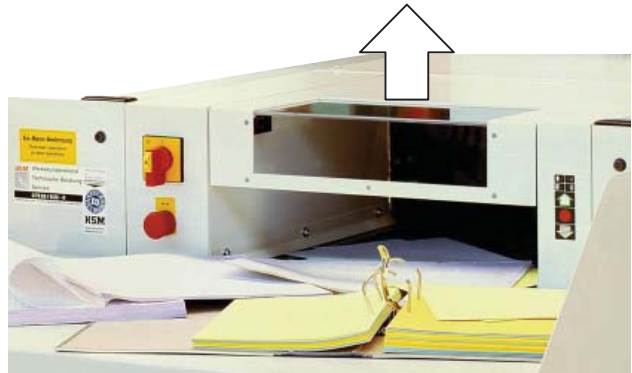

Open the safety flap.

The shredder must switch off immediately and the "Safety circuit interrupted" LED must light up.

The machine will only start again once you have closed the safety flap.

Safety switch on the dust tray

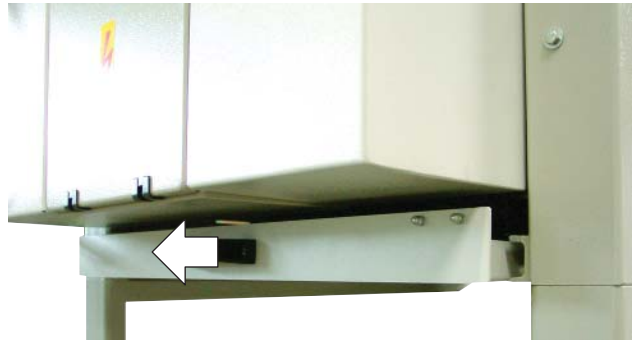

Pull out the dust tray.

The shredder must switch off immediately and the "Safety circuit interrupted" LED must light up.

The machine will only start again once you have pushed in the dust tray completely.

Safety switch on the inspection door (only stand alone-version)



Open the inspection door.
The shredder must switch off immediately and the "Safety circuit interrupted" LED must light up.

The machine will only start again once you have closed the inspection door.

Safety switch on the protective flap (only stand alone-version)

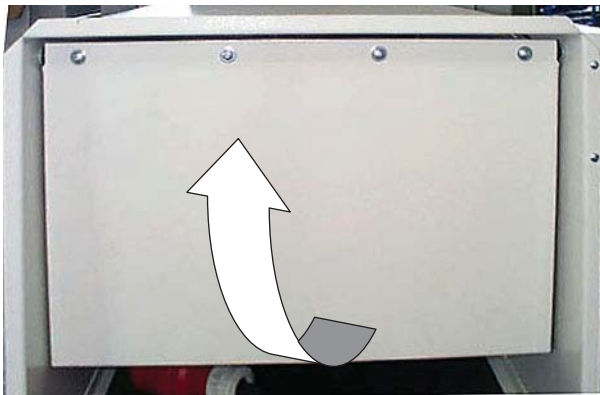

Open the protective flap.
The shredder must switch off immediately and the "Safety circuit interrupted" LED must light up.

The machine will only start again once the protective flap is in its basic (vertical) position.

Shredding material

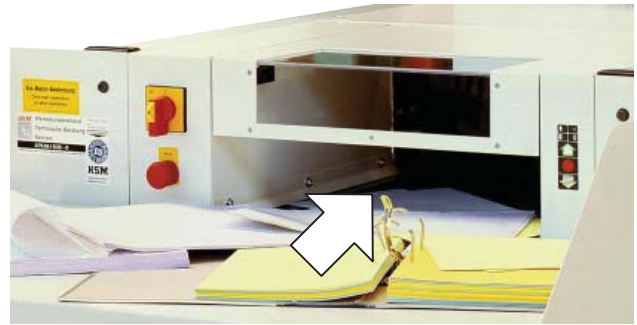

- Press the green start button.
 - ▶ The cutting block and feed belt start up.
- Place the material to be shredded on the loading tray and then place batches on the feed belt.

If material that is not supposed to be shredded is mistakenly placed onto the belt, never attempt to pull it out



- Press the stop button.
 - ▶ The drive stops.



- Press the reverse button.
 - ▶ The cutting block and feed belt run in reverse.



- You can now remove the material from the belt and start the shredder again by pressing the start button.

Stopping the shredder



- Press the stop button.
 - ▶ The cutting block and feed belt stop.
 - ▶ The shredder switches to standby mode.

Switching off the shredder



- Turn the main switch on the paper shredder or the baling press to 0. You can secure the main switch in this position using a padlock.

8 Malfunctions

Check the following before calling customer service:

- Is the power plug connected?
- Is the shredder switched on?
- Is there a paper jam in the shredder?
- Has the motor been overloaded?

Paper jam

You have fed in too much paper.



- ▶ The red LED on the keypad blinks.
- ▶ The cutting block automatically runs in reverse for several seconds.



Caution!

The blade rollers can still cause injuries even while they are not running. Do not reach into the cutting apparatus! Wear safety gloves!

- Take out the pile of paper.
- Press the green start button and put less paper on the feed belt.



Electric motor overheated



- ▶ The red LED on the keypad lights up.
- ▶ The shredder switches off automatically.
- Let the motor cool down for 20 - 30 minutes



- Press the green start button.

Safety circuit interrupted



- ▶ The red LED on the keypad lights up.
- ▶ The shredder switches off automatically.
- Check
 - Safety flap on the feed belt is closed.
 - The dust tray is pushed in completely. (only stand alone-version)
 - The inspection door is closed. (only stand alone-version)
 - The protective flap is in vertical position.



- Press the green start button.

9 Maintenance and care

Cleaning the cutting unit if the cutting quality deteriorates or the machine becomes noisy



- Let the shredder run without feeding in any paper.

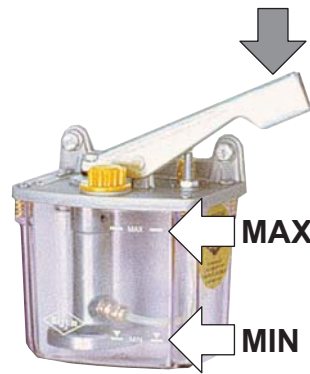

- Push the lever of the oiler down several times.
- Make sure the oil level in the container is between the MIN and MAX markings. Order no. 1.235.997.501 for 5 litre container

Emptying the dust tray

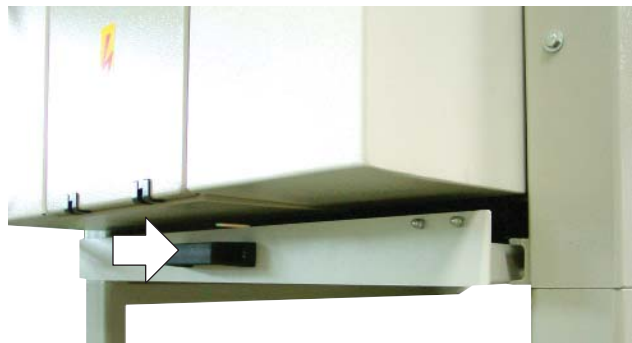

Paper dust and particles accumulate in the paper shredder during operation. To facilitate cleaning, the ground plate of the paper shredder was designed as a tray. This tray must be emptied **every week**.

Note:

The paper shredder cannot be switched on unless the dust tray is fully pushed in.

Checking the chain tension (twice yearly)



- Switch off the shredder.

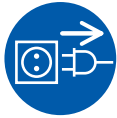

- Pull out the power plug.
- Remove the left side cover.

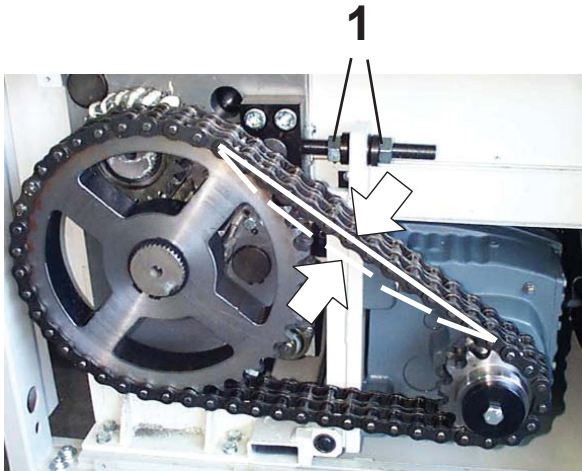

The sagging of the chain should be 9 to 14 mm.

If you need to tighten the chain:

- Loosen the clamping nuts (1).
- Lower the motor until the sagging is 9 to 14 mm.
- Tighten the clamping nuts again.
- Reinstall the cover.

Note:

Do not tighten the chain too much, as this will cause premature wear on the chain and bearings.

Greasing the drive chains and cogs (twice yearly)



- Switch off the shredder.

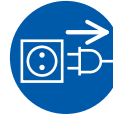

- Pull out the power plug.
- Remove the left and right side covers.
- Grease the cogs and the drive chains from the motor to the cutting apparatus, the cutting block to the feed belt and the cutting block to the regulating roller.
Recommended lubricating grease: K2K in accordance with DIN 51502/DIN 51825
- Reinstall the covers.

Maintenance work on the inlet conveyor belt

Checking the stripping device

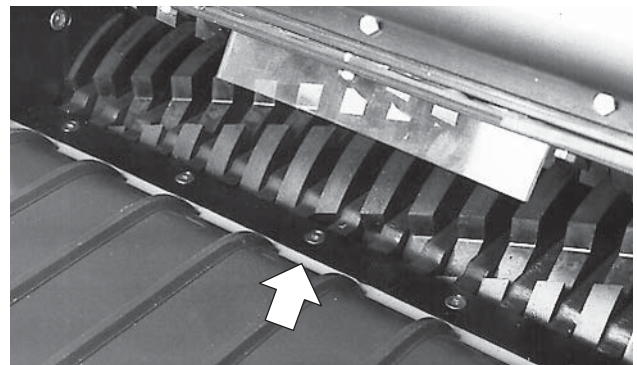

- Lift the safety flap. You can now see the stripping device.



Caution cutter rolls! Cutting injuries are possible even when the paper shredder is idle. Always wear protective gloves!

Check whether the stripping device is flush with the conveyor belt. Otherwise it must be readjusted:

- Loosen the countersunk screws of the clamping strip - this allows to move the stripping device.
- Align the stripping device and retighten the countersunk screws.

If the stripping bar is worn, it must be replaced. The area below the stripping device should be cleaned at the same time.

Tightening the feed belt

The feed belt should not slip when loaded with material.



- Switch off the shredder.
- Remove the feeding table and the left and right side covers.

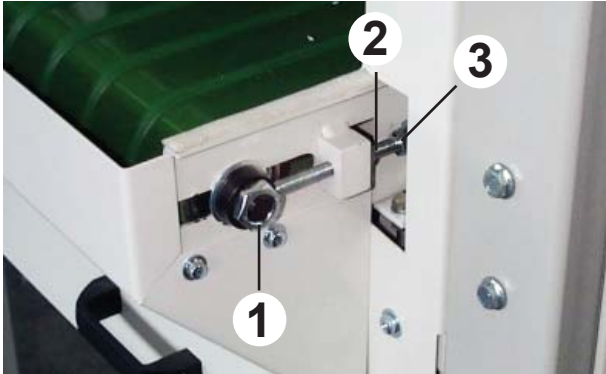

- Loosen the hexagon nuts (1) of the tension roll on the left and right side.
- Loosen the lock nuts (2) of the tensioning bolts (3).
- Tighten the feed belt **evenly** using the tensioning bolts.

Note:

Only tighten the feed belt until it stops slipping. The feed belt bearing may be damaged if it is tightened too much.

- Tighten the hex nuts on the snub roller and the lock nuts on the tensioning bolts again. Reinstall the covers and the table.



You must check that the feed belt runs straight:

Switch on the shredder and let it run for 10 minutes. During this time, the feed belt must run in the middle of the snub roller. If it slips to the left or right edge, you must alter the setting of the snub roller.

Checking the feed belt for wear

The surface of the feed belt can become worn after long periods of use. If you can see the fabric inlay in the belt, it must be replaced. Please notify our customer service.

Cleaning the shredder:

- Switch off the shredder and disconnect the mains plug.
- When cleaning, only use a soft cloth and a mild soap-water solution. Never use scouring agents, cleaning fluid, petroleum or thinners.

Cleaning the tensioning station (monthly)

- Remove the feeding table and the front panel of the tensioning station.
- Remove particles and dirt.

Cleaning the conveyor-belt area (monthly)

- Remove the covers on both sides. The cleaning openings in the conveyor-belt covers are now accessible.
- Blow out the conveyor-belt area with compressed air or use a vacuum cleaner to remove the dirt particles.

Checking the stripping brush (monthly)

- Remove the covers on both sides. The stripping brush below the conveyor belt is now accessible. If the stripping brush is not flush with the conveyor belt, you must re-adjust the stripping brush:
 - Loosen the brush supports on the left and on the right.
 - Re-adjust the brush support with the brush upwards.
 - Screw the brush support back on.

10 Technical Data

Cutting type	Cross cut		
Cut size (mm)	10.5 x 40 - 76	7.5 x 40 - 80	6 x 40 - 53
Safety level DIN 32757 – 1	2	2	3
Cutting capacity (sheets), DIN A4, 70 g/m ² 80 g/m ²	600 - 650 510 - 550	500 - 550 425 - 470	400 - 450 340 - 350
Cutting speed	210 mm/s		
Effective width	500 mm		
Weight	approx. 725 kg		
Voltage	3 x 400 V, 50 Hz		
Rated power	9.2 kW		
Rated current	18.1 A		
Fuse rate	32 A		
Plug	CEE 32A		
Ambient conditions in operation: Temperature Relative humidity Height above sea-level (MSL)	-10 °C to +40 °C max. 90 %, without condensation max. 2,000 m		
Sound level (idling / under load)	63 dB(A) / 80 dB(A)		

EC Declaration of Conformity

The manufacturer **HSM GmbH + Co. KG**, Austrasse 1 - 9, D-88699 Frickingen hereby declares that the machine, referred to here as document shredder **HSM FA 500.2** corresponds to the health and safety requirements of the following EC directives listed below due to its conception and design of the version in which it was put into circulation by us:

Machinery directive 2006 / 42 / EC
EMC directive 2004 / 108 / EC

Applied standards and technical specifications:

- EN 349:1993 + A1:2008
- EN 12100-1:2003 + A1:2009
- EN 55014-1:2006
- EN 61000-3-2:2006
- EN 61000-3-3:1995 + A1:2001 + A2:2005
- EN 62061:2005
- EN 12100-2:2003 + A1:2009
- EN 55014-2:1997 + A1:2001
- EN 60950-1:2006

Authorised representative for the compilation of technical documentation:
Rolf Gasteier, HSM GmbH + Co. KG

Frickingen, 11.02.2010

Rolf Gasteier - Technical Director

The machine type was tested for compliance with the requirements of the EU Machinery Directive by:
TÜV Rheinland LGA Products GmbH, Tillystrasse 2, 90431 Nürnberg / Germany.
This test centre is responsible in accordance with Appendix XI of the EC Machinery Directive.

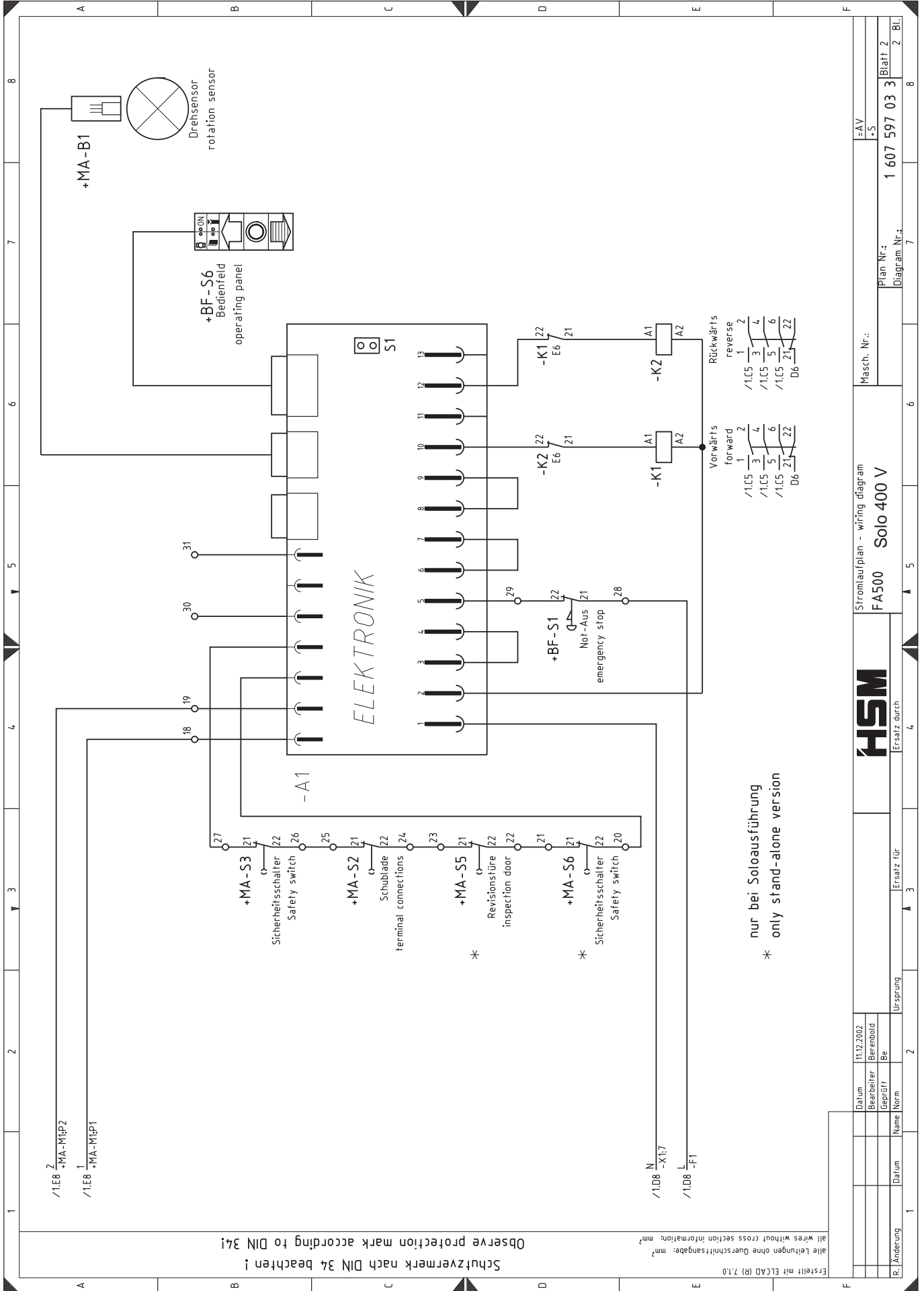

Erstellt mit ELCAD (R) 7.1.0
 alle Leitungen ohne Querschnittsangaben: mm²
 all wires without cross section information: mm²
 Schutzvermerk nach DIN 34 beachten!
 Observe protection mark according to DIN 34!

* nur bei Soloausführung
 * only stand-alone version

R. Änderung		Datum		Name		Norm		Ursprung		Ersatz für		Ersatz durch	
Stromlaufplan - wiring diagram												Masch. Nr.:	
FA500 Solo 400 V													
Plan Nr.:												1 607 597 03 3	
Diagramm Nr.:												Blatt 2	
												2 Bl.	

Combination 400 V / 50 Hz

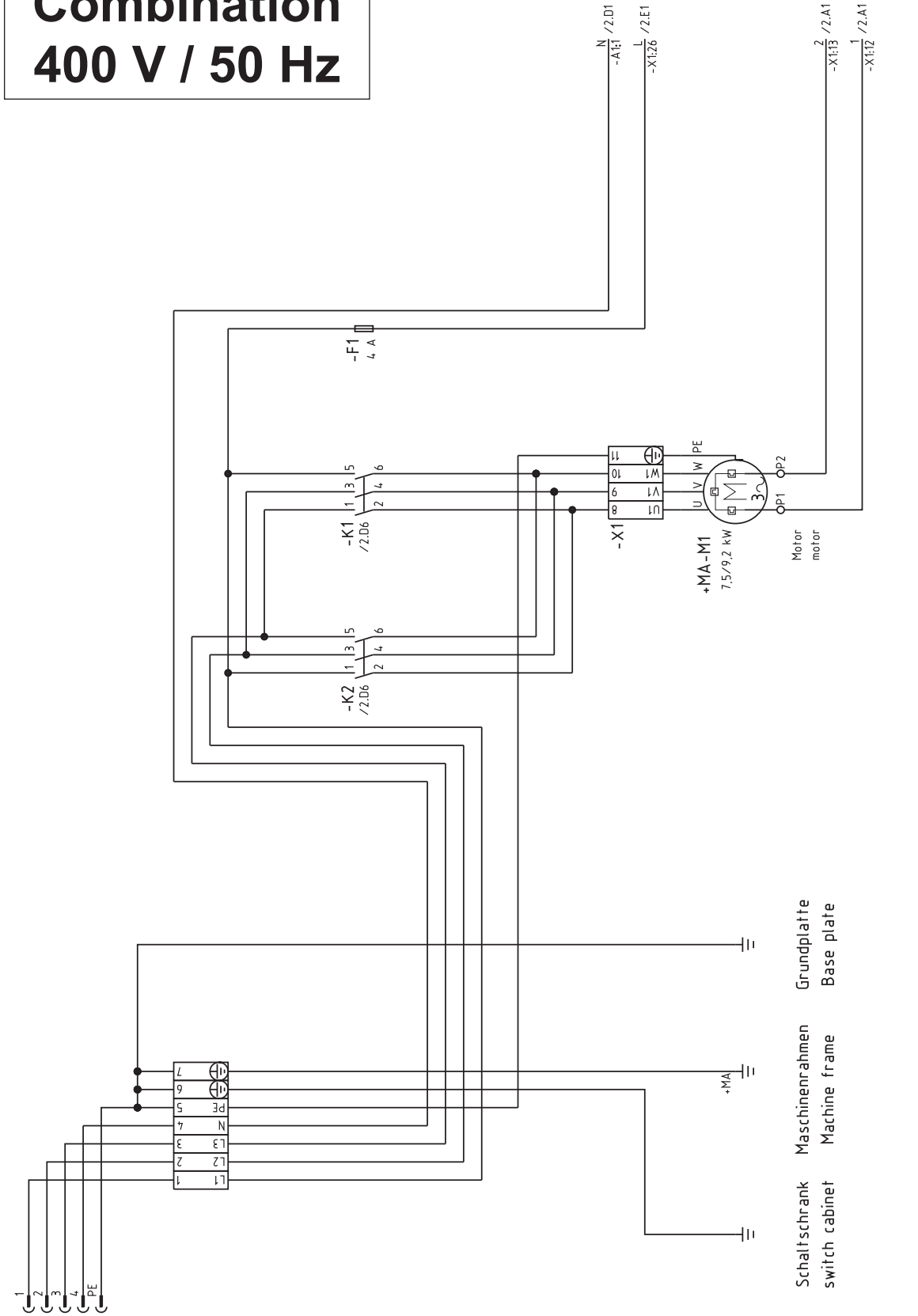

Schutzvermerk nach DIN 34 beachten!
 Observe protection mark according to DIN 34!

Erstellt mit ELCAD (R) 7.10
 alle Leitungen ohne Querschnittsangaben: mm²
 all wires without cross section information: mm²

Schaltschrank Maschinenrahmen Grundplatte
 switch cabinet Machine frame Base plate

R. Änderung		Name		Datum		1	
Ursprung		Ersatz für		3		2	
Datum		11.12.2002		Bereitend		2	
Bearbeiter		Berenbold		Geprüft		Be	
HSM				Ersatz durch			
Stromlaufplan - wiring diagram				Masch. Nr.:			
FA500.x				Kombi 400 V			
1 607 597 03 5				Blatt 1			
Diagram.Nr.:				2. Bl.			

Schutzvermerk nach DIN 34 beachten !		Observe protection mark according to DIN 34!	
Kabelbezeichnung cable designation		Kabelbezeichnung cable designation	
frei	0	frei	0
Zielfeld intern target char. internal	Zielfeld extern target char. external	Zielfeld intern target char. internal	Zielfeld extern target char. external
Anschlußleiste terminal board		Anschlußleiste terminal board	
Klemmenkommentar comment		Klemmenkommentar comment	
Darstellungsort location		Darstellungsort location	
Betriebsmittel device		Betriebsmittel device	
Anschlußbezeichnung connection		Anschlußbezeichnung connection	
Leiste : -X7		Leiste : -X7	
Klemmenanzahl : 9		Klemmenanzahl : 9	
AV/1A1		AV/1A1	
AV/1A1		AV/1A1	
AV/1A1		AV/1A1	
AV/1A1		AV/1A1	
AV/1A1		AV/1A1	
AV/1A1		AV/1A1	
AV/2F4		AV/2F4	
AV/2F4		AV/2F4	
AV/2F4		AV/2F4	
AV/2F5		AV/2F5	
AV/2F5		AV/2F5	
AV/1A1+S		AV/1A1+S	
PE		PE	
AV+S-X1 1		AV+S-X1 1	
AV+S-X1 2		AV+S-X1 2	
AV+S-X1 3		AV+S-X1 3	
AV+S-X1 4		AV+S-X1 4	
AV+S-X1 5		AV+S-X1 5	
AV+S-X1 6		AV+S-X1 6	
AV+S-X1 7		AV+S-X1 7	
AV+S-X1 8		AV+S-X1 8	
AV+S-X1 29		AV+S-X1 29	
AV/1A1+S		AV/1A1+S	
X		X	



Klemmenplan - terminal connections
FA500.x
=BP+S-X7

Kombi 400 V

=BP+S

1 607 598 03 5

Blatt 2
2 Bl.

13.01.2003

Datum
Bearbeiter
Geprüft

Datum
Name
Norm

Rt. Änderung
Ursprung
Ersatz für
Ersatz durch

Erstellt mit ELCAD (R) 7.1.0